

The background of the advertisement is a photograph of two women standing in a modern elevator. The woman on the left is wearing a dark blue, sleeveless dress and is holding a pink smartphone up to take a selfie. The woman on the right is wearing a bright blue, short-sleeved top and dark pants, and is holding a green smartphone. They are both smiling and looking towards the camera. The elevator interior has dark, metallic-looking walls and a glass door with a grid pattern.

UPGRADE YOUR BUILDING WITH A MODERN, CONNECTED ELEVATOR

THE TOP-TO-BOTTOM RENEWAL FOR YOUR ELEVATOR

Even with proper maintenance, all elevators need thorough modernization eventually. After several years, parts will need replacing and you'll probably find that repair bills start to rise.

Finding spare parts can also become a problem. After 25 years of service or more, you can find yourself facing issues with safety and reliability.

Compared to modern elevators, older elevators consume more power and can also contain outdated technology. The hoisting machine in particular will probably have poor energy efficiency and might be the cause of frequent breakdowns. All of this can have an impact on the value of your building. After 25 years and 6213 miles*, is it time to think about giving your elevator a new lease on life?

Cut costs and reduce hassles while improving reliability and safety

KONE ReGenerate™ DX is a comprehensive controller and hoisting modernization solution that can save you a considerable amount of money and inconvenience over your elevator's lifetime. The modernization is based on KONE EcoDisc™ hoisting technology, which can significantly cut your elevator's operating costs and also improve its reliability. KONE ReGenerate™ DX also improves the safety and accessibility of your elevator. Additional benefits of modernization include accurate leveling with landing floors, which helps reduce the risk of people tripping on the elevator sill, and new safety devices that monitor uncontrolled car movement and prevent overspeed when the car is ascending.

Key benefits

- Improves elevator energy efficiency, reliability, and safety
- Improves accessibility with accurate leveling
- New safety devices monitor uncontrolled car movement and prevent overspeed
- Minimizes elevator downtime with quick installation
- Complies with all relevant North American safety and accessibility standards

Looking for a safer elevator with better performance?

We offer solutions for offices, hotels, and retail premises that involve the complete replacement of your elevator's electrification and hoisting systems. The new machine is equipped with a silent brake that minimizes noise disturbance. For extra peace of mind, you can also add our KONE 24/7 Emergency Video Communication* system that passengers can use to contact our KONE Customer Care Center in case of emergencies.

Robust, reliable components and faster fault diagnosis

KONE ReGenerate™ DX components are designed to be robust and reliable. Fully encapsulated circuit boards keep out dust and foreign objects and reduce the risk of electrostatic discharge. The modernization also includes a modern safety system that automatically identifies faults at the switch level and shows them on a display that technicians can use to quickly diagnose problems.

Lower power consumption means lower operating costs

Our gearless and oil-free KONE EcoDisc® hoisting machines cut the energy consumption of your elevator by using a low starting current to ensure high electrical efficiency. For traction elevators, our Variable Voltage, Variable Frequency (V3F) drive control significantly reduces energy consumption. You can save even more power with our advanced standby features that power down certain functions when the elevator isn't being used. Further energy savings are achieved with the inclusion of a regenerative drive module.

*This capability may be required by code in your jurisdiction.

A NEW ERA OF ELEVATOR EXPERIENCE

In an increasingly digitalized world, everything is connected – and elevators are no exception. With the KONE ReGenerate™ DX solution, you can create a completely new kind of elevator experience.

DX stands for digital experience, because with the KONE ReGenerate™ DX solution you can create an experience that really connects – on every level. Connectivity lets you benefit from improved people flow plus a variety of innovative new services to make everyday life even easier and more enjoyable.

By making the core of your building updateable, you're investing in the value of your building by preparing for future needs and functionality.



1

Get connected for smooth people flow

With connectivity and KONE application programming interfaces (APIs), you can make your elevator smarter and more desirable with new people flow solutions and value-adding services from KONE and our partners. By upgrading an existing elevator, you can optimize people flow and operational efficiency while also making sure your property is ready to take advantage of future smart-building technologies.*

2

Redefine the user experience

With real-time information for passengers, engaging user experiences, and other smart building applications, you can redefine elevator rides in your building and improve everyday convenience with enhanced accessibility and equipment availability.

3

Plan for success with KONE as your partner

As your experienced partner for smart buildings, we can help you manage your property more efficiently with valuable insights into end-user behavior that can be used to continuously optimize people flow and improve the user experience.

*Subject to building compatibility.

Easy to upgrade

Connectivity gives you the possibility to upgrade in the future as your needs change by adding new connected services and features whenever you need them.

Best-in-class eco-efficiency

Save energy and cut your building's carbon footprint with our eco-efficient hoisting, lighting, and standby solutions.

Upgrade performance and reliability

By refreshing your elevator's mechanical and electrical components, you can significantly improve its performance and reliability.

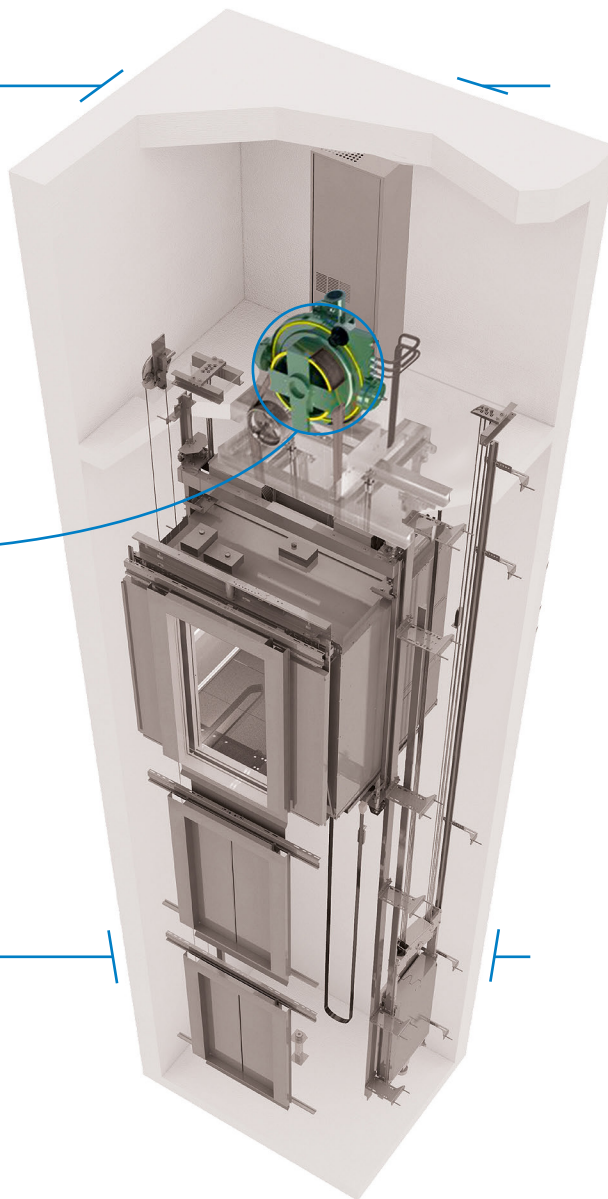

FUTURE-PROOF YOUR BUILDING WITH CONNECTIVITY

We have added connectivity to make the KONE ReGenerate™ DX solution smarter, to optimize people flow and enable increased operational efficiency.

Connected people flow means your elevator solution never stands still, and it's easy to upgrade – evolving with your building, adding value, and increasing the attractiveness of the property to prospective tenants.

To bring you peace of mind in the digital world, cybersecurity and privacy are designed into our digital services and connections. We continuously monitor the security of the digital environment and the reliability of the connectivity.

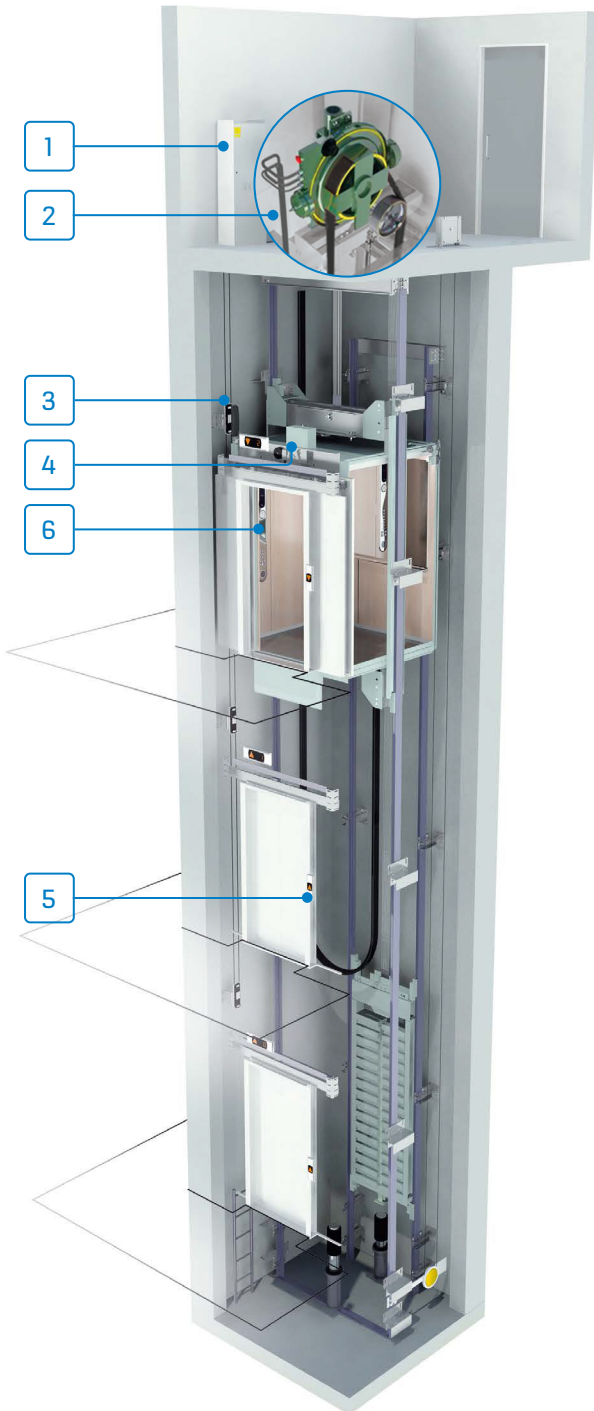

KONE REGENERATE™ DX INCLUDES:

- | | | | |
|---|--|---|---|
| 1 | KONE ReGenerate™ DX controller cabinet | 4 | Door operator interface |
| 2 | New hoisting machinery | 5 | Signalization |
| 3 | Positioning system | 6 | KONE 24/7 Emergency Video Communications (Optional) |

PLAN FOR SUCCESS WITH KONE AS YOUR PARTNER

Continuously optimize people flow and improve the user experience in your building with the assistance of an experienced partner. We can help you make your building smarter with valuable insights based on a holistic view of end-user behavior and people flow.

We work with an ecosystem of partners to provide new services and solutions, and through our People Flow Planning and Consulting service we can help move people smoothly and safely around your building. We can also help you make better investment planning decisions based on solid data, and

provide sustainable technologies, materials, and services that contribute to credits and certifications for green-building accreditation.

UPGRADE WITHOUT THE HASSLE

On time and on budget, with no surprises, that's our promise. We take care of everything, from planning the project to updating your elevator. We'll also provide technical and safety information and training when we hand it over to you, as well as provide support with any third-party inspections required. We can also make sure your elevator operates reliably and safely for its entire lifespan with a customized KONE Care™ preventive maintenance package.

FOUR EASY STEPS TO AN UPGRADED ELEVATOR

1 Fact-finding



- We'll carry out a detailed site survey to learn more about what kinds of upgrades would be best for your elevator and building.
- As part of this process, we'll talk to key stakeholders to learn what they want to get out of the project.

2 Recommendation and estimate



- You'll get a clear recommendation about what to upgrade based on your needs and our expert opinion.
- We'll provide a detailed schedule and cost breakdown so you know what to budget for and how long the project will take.

3 Execution



- Once the project is underway, a KONE project manager will be responsible for quality checks and supervision throughout the process.
- We'll keep everyone fully informed about the schedule and progress of the work. We can even provide KONE InfoMod information boards for building lobbies to keep tenants informed of the progress.

4 Ongoing maintenance and care



- We can create a tailored KONE Care™ maintenance plan for your equipment to keep it running safely and smoothly.
- With KONE 24/7 Connected Services*, we can monitor your equipment around the clock and take proactive action to prevent potential problems from causing a breakdown.

*Separate agreement and charges apply. KONE maintenance agreement required. KONE not responsible for third-party wireless service interruptions.



KONE provides innovative and eco-efficient solutions for elevators, escalators and the systems that integrate them with today's intelligent buildings.

We support our customers every step of the way: from design, manufacturing and installation to maintenance and modernization. KONE is a global leader in helping our customers manage the smooth flow of people and goods throughout their buildings.

Our commitment to customers is present in all KONE solutions. This makes us a reliable partner throughout the life cycle of the building. We challenge the conventional wisdom of the industry. We are fast, flexible, and we have a well-deserved reputation as a technology leader, with such innovations as KONE MonoSpace® DX, KONE EcoMod® and KONE UltraRope®.

KONE employs over 60,000 dedicated experts to serve you globally and locally.

KONE AMERICAS HEADQUARTERS

4225 Naperville Road
Lisle, IL 60532
Tel. (630) 577-1650

www.kone.us

Upgrade your building with a modern, connected elevator. Scan this code or visit our website to get in touch with a KONE Sales Professional:

kone.us/rgdx

